

Acqiris SA220P Acquisition Card

2 channels, 14-bit, 2 GS/s or 1 GS/s,
DC to 1.2 GHz bandwidth
with real-time processing

Start-up Guide



Notices

© Acqiris, 2017 - 2022

No part of this manual may be reproduced in any form or by any means (including electronic storage and retrieval or translation into a foreign language) without prior agreement and written consent from Acqiris SA as governed by international copyright laws.

Contact us

Feel free to contact Acqiris experts and send an email to support@acqiris.com - Worldwide contact for support or repair.

For any question or inquiry, you can also contact your local office:

Acqiris Americas
contact-americas@acqiris.com

Acqiris Europe
contact-emea@acqiris.com

Acqiris Asia-Pacific
contact-asia-pacific@acqiris.com

Acqiris Japan
contact-japan@acqiris.com

Conventions Used in this Document

The following conventions are used in this document:

Warning

A WARNING denotes a hazard. It calls attention to an operating procedure, practice, or the like that, if not correctly performed or adhered to, could result in personal injury or death. Do not proceed beyond a WARNING until the indicated conditions are fully understood and met.

Caution

A CAUTION denotes a hazard. It calls attention to an operating procedure, practice, or the like that, if not correctly performed or adhered to, could result in damage to the product or loss of important data. Do not proceed beyond a CAUTION until the indicated conditions are fully understood and met.

Note

A NOTE draws the reader's attention to important information, caveats, etc...

Important

An IMPORTANT section specifically requires the reader's attention.

Safety Notes

The following safety precautions should be observed before using this product and any associated instrumentation. The "product" refers to the SA220P signal acquisition card.

This product is intended for use by qualified personnel who recognize shock hazards and are familiar with the safety precautions required to avoid possible injury. Read and follow all installation, operation, and maintenance information carefully before using the product.

Warning

If this product is not used as specified, the protection provided by the equipment could be impaired. This product must be used in a normal condition (in which all means for protection are intact) only.

The types of product users are:

- **Responsible body** is the individual or group responsible for the use and maintenance of equipment, for ensuring that the equipment is operated within its specifications and operating limits, and for ensuring operators are adequately trained.
- **Operators** use the product for its intended function. They must be trained in electrical safety procedures and proper use of the card. They must be protected from electric shock and contact with hazardous live circuits.
- **Service personnel** are trained to work on live circuits, perform safe installations, and repair products. Only properly trained service personnel may perform installation and service procedures.

Operator is responsible to maintain safe operating conditions. To ensure safe operating conditions, cards should not be operated beyond the full temperature range specified in the datasheet. Exceeding safe operating conditions can result in shorter lifespans, improper card performance and user safety issues. When the cards are in use and operation within the specified full temperature range is not maintained, card surface temperatures may exceed safe handling conditions which can cause discomfort or burns if touched. In the event of a card exceeding the full temperature range, always allow the card to cool before touching or removing cards from host computer or chassis.

Exercise extreme caution when a shock hazard is present. Lethal voltage may be present on cable connector jacks or test fixtures. The American National Standards Institute (ANSI) states that a shock hazard exists when voltage levels greater than 30 V RMS, 42.4 V peak, or 60 V DC are present. A good safety practice is to expect that hazardous voltage is present in any unknown circuit before measuring.

Operators of this product must be protected from electric shock at all times. The responsible body must ensure that operators are prevented access and/or insulated from every connection point. In some cases, connections must be exposed to potential human contact. Product operators in these circumstances must be trained to protect themselves from the risk of electric shock. If the circuit is capable of operating at or above 1000 V, no conductive part of the circuit may be exposed.

Do not connect cards directly to unlimited power circuits. They are intended to be used with impedance-limited sources. NEVER connect cards directly to AC mains. When connecting sources to cards, install protective devices to limit fault current and voltage to the card. Before operating a card, ensure that the line cord is connected to a properly-grounded power receptacle. Inspect the connecting cables, test leads, and jumpers for possible wear, cracks, or breaks before each use.

When installing equipment where access to the main power cord is restricted, such as rack mounting, a separate main input power disconnect device must be provided in close proximity to the equipment and within easy reach of the operator.

For maximum safety, do not touch the product, test cables, or any other instruments while power is applied to the circuit under test. ALWAYS remove power from the entire test system and discharge any capacitors before: connecting or disconnecting cables or jumpers, installing or removing ADC cards, or making internal changes, such as installing or removing jumpers.

Do not touch any object that could provide a current path to the common side of the circuit under test or power line (earth) ground. Always make measurements with dry hands while standing on a dry, insulated surface capable of withstanding the voltage being measured.

The card and accessories must be used in accordance with its specifications and operating instructions, or the safety of the equipment may be impaired.

Do not exceed the maximum signal levels of the cards and accessories, as defined in the specifications and operating information, and as shown on the card or test fixture panels, or ADC card.

If you are using a test fixture, keep the lid closed while power is applied to the device under test. Safe operation requires the use of a lid interlock.

Cards, modules and accessories shall not be connected to humans.

Before performing any maintenance, disconnect the line cord and all test cables. Any part or component replacement must be done by Acqiris.

Warning No operator serviceable parts inside. Refer servicing to qualified personnel. To prevent electrical shock do not remove covers.

Cleaning Precautions

Warning To prevent electrical shock, disconnect the ADC card from mains before cleaning. Use a dry cloth or one slightly dampened with water to clean the external case parts. Do not attempt to clean internally. To clean the connectors, use alcohol in a well-ventilated area. Allow all residual alcohol moisture to evaporate, and the fumes to dissipate prior to energizing the card.

Product Markings



The CE mark is a registered trademark of the European Community.



Australian Communication and Media Authority mark to indicate regulatory compliance as a registered supplier.

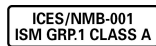

This symbol indicates product compliance with the Canadian Interference-Causing Equipment Standard (ICES-001). It also identifies the product is an Industrial Scientific and Medical Group 1 Class A product (CISPR 11, Clause 4).



This product complies with the WEEE Directive marketing requirement. The affixed product label (above) indicates that you must not discard this electrical/electronic product in domestic household waste. **Product Category:** With reference to the equipment types in the WEEE directive Annex 1, this product is classified as “Monitoring and Control instrumentation” product. To return unwanted products, contact your local Acqiris office.



This symbol on an instrument means caution, risk of danger. You should refer to the operating instructions located in the user documentation in all cases where the symbol is marked on the instrument.



This symbol indicates the time period during which no hazardous or toxic substance elements are expected to leak or deteriorate during normal use. Forty years is the expected useful life of the product.



This symbol indicates the instrument is sensitive to electrostatic discharge (ESD). ESD can damage the highly sensitive components in your instrument. ESD damage is most likely to occur as the module is being installed or when cables are connected or disconnected. Protect the circuits from ESD damage by wearing a grounding strap that provides a low resistance path to ground. Alternatively, ground yourself to discharge any built-up static charge by touching the outer shell of any grounded instrument chassis before touching the port connectors.



This symbol denotes a hot surface. The side cover of the module will be hot after use and should be allowed to cool for several minutes.



The FCC certification mark certifies that the electromagnetic interference from the device is under limits approved by the Federal Communications Commission.

Contents

| | |
|--|----|
| Notices | 2 |
| Contact us | 2 |
| Conventions Used in this Document | 3 |
| Safety Notes | 3 |
| Cleaning Precautions | 5 |
| Product Markings | 6 |
| Contents | 7 |
| Introduction | 8 |
| Step 1: Unpack and Inspect the Card | 8 |
| Electrostatic Discharge (ESD) Precautions | 8 |
| Inspect for Damage | 8 |
| Return a Card for Service | 9 |
| Step 2: Verify SA220P Shipment Contents | 9 |
| Step 3: Install the Software | 10 |
| System Requirements | 10 |
| Hardware Requirements | 10 |
| Software installation for Windows users | 10 |
| Specific requirement for Windows 10 users | 11 |
| Software installation for Linux users | 11 |
| Step 4: Install the Card | 12 |
| Fitting the card with the optional card retainer | 13 |
| Removing the card retainer | 14 |
| Reversing the orientation of the fan assembly | 14 |
| SA220P Front Panel Features | 15 |
| Front Panel Connectors | 15 |
| Front Panel LEDs | 16 |
| Startup sequence | 16 |
| Step 5: Verify Operation of the SA220P Card | 17 |
| Driver Graphical Interface: MD3 Soft Front Panel | 17 |
| Perform a Verification of the SA220P (optional) | 17 |
| Requirements for Verification | 17 |
| Required Hardware | 18 |
| Operational Verification Procedure | 18 |
| If a Problem is Found | 19 |
| Related Documentation | 20 |
| Programming Information | 21 |
| IVI-C Driver development environments | 21 |
| IVI.NET Driver development environments | 21 |
| Program examples | 21 |

Introduction

The scope of this Startup Guide is to detail the processes of receiving and installing the Acqiris SA220P signal acquisition card, installing the required software, and verifying basic card operation.

If you have any questions after reviewing this information, please contact technical support support@acqiris.com.

Warning

Closely follow the startup process flow in this document. Deviating from the sequence can cause unpredictable system behavior, damage your system, and may cause personal injury.

Step 1: Unpack and Inspect the Card

Caution

The card is shipped in materials which prevent damage from electrostatic discharge. The card should only be removed from the packaging in an anti-static area ensuring that correct anti-static precautions are taken. Store all cards in anti-static pouch when not in use.

Electrostatic Discharge (ESD) Precautions

Electrostatic discharge (ESD) can damage or destroy electronic components. Use a static-safe work station to perform all work on electronic assemblies. A static-safe work station uses, for instance, two types of ESD protection: conductive table-mat and wrist-strap combination, and conductive floor-mat and heel-strap combination. Both types, when used together, provide a significant level of ESD protection. Of the two, only the table-mat and wrist-strap combination provides adequate ESD protection when used alone. To ensure user safety, the static-safe accessories must provide at least 1 M Ω of isolation from ground.

Warning

DO NOT use these techniques for a static-safe work station when working on circuitry with a voltage potential greater than 500 volts.

Inspect for Damage

After unpacking the SA220P card, inspect it for any shipping damage. Report any damage to the shipping agent immediately, as such damage is not covered by the warranty (see warranty information attached to the original quote or order confirmation from Acqiris).

Caution

To avoid damage when handling a card, do not touch any exposed components or connector pins.

Return a Card for Service

Should it become necessary to return a card for repair or service, follow the steps below:

1. Review the warranty information attached to the original quote or order confirmation from Acqiris.
2. To obtain a Return Material Authorization (RMA) and return address, contact Acqiris at support@acqiris.com, providing the following information:
 - Product model number (for example: SA220P).
 - Product serial number (for example: AQ00070xxx, US00075xxx or MY00090xxx). The serial number label is located on a sticker:
 - On the top edge of the card, for units shipped after July 2018.
 - On the side panel of the card, for units shipped before July 2018.
 - The serial number can also be read from the Soft Front Panel interface, but only after the hardware and software are installed.
 - Name and address of owner (a P.O. box is not acceptable as a return address).
 - A description of the failure or service requested.
4. Pack the card in its original ESD bag and packing carton. If the original carton is not available, use bubble wrap or packing peanuts and place the product in a sealed container and mark the container "FRAGILE".

Note

If any correspondence is required, refer to the product by serial number, and model number or RMA number.

Step 2: Verify SA220P Shipment Contents

The shipment content and accessories depends on your order.

Please refer to the packing list for details.

Step 3: Install the Software

System Requirements

| Requirements | Windows | Linux |
|----------------------|--|---|
| Operating system | Windows 10 (32 or 64-bit), all versions Windows 11, all versions | Linux Kernel 4 or higher (32 or 64-bit), Debian, Ubuntu, CentOS |
| Processor speed | 1 GHz 32-bit (x86), 1 GHz 64-bit (x64), no support for Itanium 64 | As per the minimum requirements of the chosen distribution |
| Available memory | 1 GB minimum ¹ | As per the minimum requirements of the chosen distribution |
| Available disk space | 1 GB available hard disk space | 2 GB |
| Display | Minimum of 1024 x 768 | No display required |
| Temperature range | Check upon environment requirement. Might not allow to go as high as ADC card allows. | |

¹ On older computers with minimum RAM, installation can take a long time when installing the .NET Framework.

Hardware Requirements

A host computer running one of the above operating systems.

Recommended models are: HP Z4 (G4 and G5) or Dell 5820 –for the Dell 5820 a specific procedure is required: please contact technical support support@acqiris.com.

The computer should be configured to have the following installed:

- The latest BIOS version.

Warning

To avoid damage and risk due to fire a host computer with metal shielding is highly recommended.

Software installation for Windows users

Important

If a previous version of the Acqiris MD3 Software for Signal Acquisition Cards is installed on your computer, first uninstall it before installing the new software version.

Acqiris MD3 Software for Signal Acquisition Cards includes the latest Acqiris device driver AqMD3 (IVI-C, IVI.NET) and product documentation.

1. Download Acqiris MD3 from Acqiris Extranet <https://extranet.acqiris.com/> or directly from <https://acqiris.com/md3> (Creating an account is not required: just scroll down and select your product)..
2. After downloading Acqiris MD3 Software for Signal Acquisition Cards, double click on the executable to launch the installer.
3. Follow the installer prompts. Choose a **Complete installation** to install all software and documentation, or a **Custom installation** to select from a listing of components and other features.
4. After installation is complete, please select **Restart**.

Specific requirement for Windows 10 users

As security standard, starting with Windows 8.1, Microsoft has introduced the concept of "Secure Boot".

Windows 10 includes this process that does not allow a kernel driver to access to the hardware if the driver has not been certified by Microsoft.

Acqiris guarantees that the software provided is safe even if it is not recognized by Microsoft Secure boot.

Consequently, Secure boot must be disabled in order to use the driver.

The procedure is available here:

<https://docs.microsoft.com/en-us/windows-hardware/manufacture/desktop/disabling-secure-boot>.

Software installation for Linux users

To install the MD3 Software to run on Linux you need to have a Linux system running with kernel version 2.6, 3 or 4.

Package files are available for some popular distributions. The distribution specific directories contains packages that are specific for this distribution and should be installed

1. Extract the compressed archive *LinuxMD3-M.m.b.tar.gz*.
2. Refer to the *README* file for more information about the installation.

Step 4: Install the Card

1. Ensure that the host computer is switched off, and disconnect the power cord. Open the host computer case.

Caution

Follow ESD precautions when handling and installing the SA220P.

Caution

Be careful there is no mechanical part of the host computer that could damage the power adapter cable.

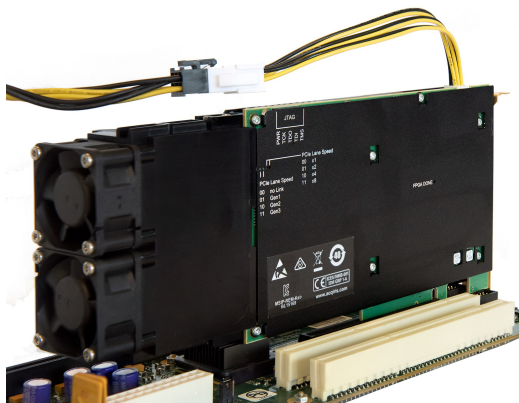

2. The SA220P features a x8 PCIe bus interface, and should be installed in either a x8 or x16 PCIe slot.
3. When installing the SA220P, ensure that it has optimum cooling. Do not install it in a position where the integrated cooling fans may be obstructed.
4. The card requires an additional auxiliary 6-pin power connection to one of the internal power supply of the host computer, using the 6-pin PCIe 12V power cable connector shipped with your product (U5320A-21001).
5. Replace any covers and switch on the computer. Check the card front panel indicators - a few seconds after the boot process, the 'Status' LED should be blinking.

Fitting the card with the optional card retainer

A card retainer is recommended if the card is assembled horizontally or in harsh environment.

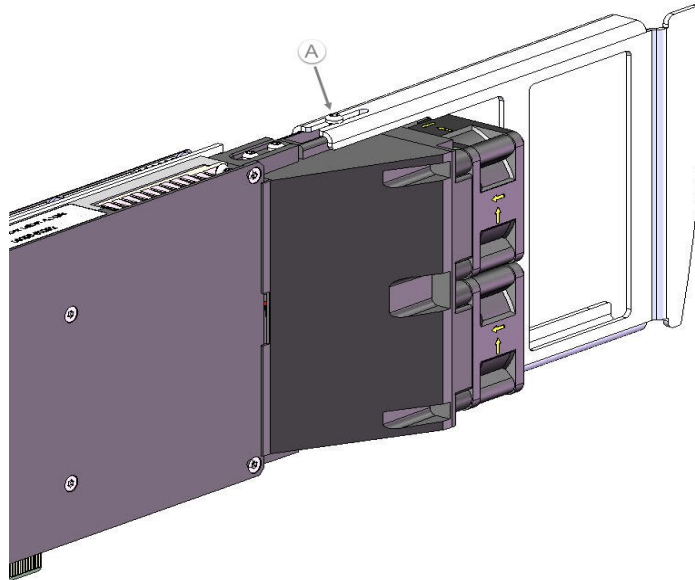

Diagram showing SA220P retainer assembly fixing.

If you have ordered your product with this option or if you have ordered a card retainer as an accessory:

1. Loosen (but do not remove) the screw (A) holding the rear card retainer, and slide it towards the fans. Note that there are screws only on the top side: there is no screw on the bottom side.
2. Insert the card into the PCIe slot of the PC, ensuring that it is fully seated into the PCIe bus connector.
3. Fix the card to the host computer either by fitting a screw, or by using a method compliant with your host computer model.
4. Fully extend the card retainer and ensure that it is inside the host computer chassis support slot.
5. Tighten the screw (A) using a 0.5 Nm torque.

Note

If the host computer is a Dell T5810, the PCIe card retention (support slots) has to be removed and adapted by removing two of the extension blocks before inserting the SA220P. For details, please contact technical support support@acqiris.com.

Removing the card retainer

1. Remove the screw (A in the figure).
2. Withdraw the card retainer.

Reversing the orientation of the fan assembly

It is also possible to reverse the orientation of the fan assembly, for instance in the case that two cards must be placed in adjacent slots, or another host computer hardware obstructs the fitting. This procedure is detailed below.

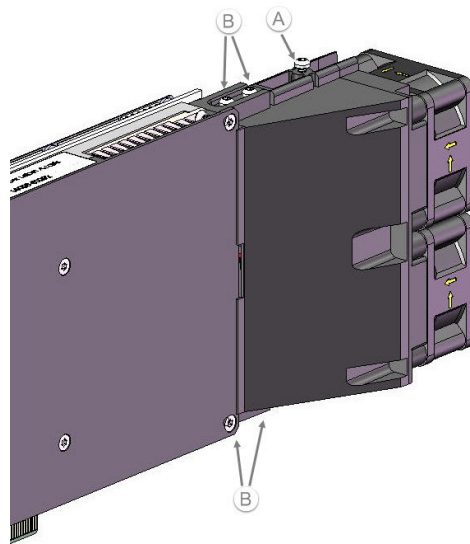

SA220P fan assembly fixing.

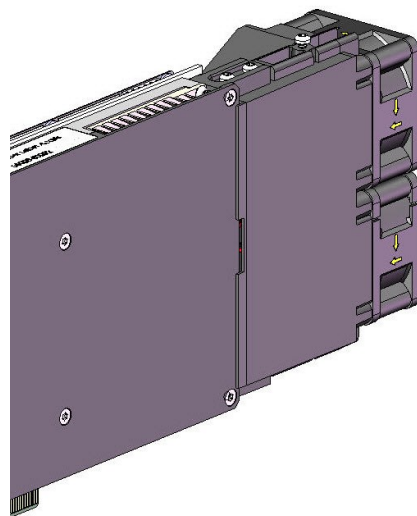

SA220P with reversed fan assembly.

1. Remove the four screws (B) nearest to the front of the fan unit.
2. Carefully, slide the fan unit approximately 15 mm to the rear until it clears the circuit board, keeping the fan unit level with the card both horizontally and vertically and rotate the fan unit by 180°, without disconnecting the fan power cables.
3. Slide the fan unit back towards the card, keeping the fan unit level with the card both horizontally and vertically, until the card is fully seated into the support slots.
4. Refit the four screws (B), push the fan unit upwards away from the circuit board and tighten the four screws using 0.5 torque.
5. If the card has a card retainer: before fitting the card in the retainer, the screw (A) should be removed and refit of the opposite side of the fan, as illustrated on the left.

SA220P Front Panel Features

Front Panel Connectors

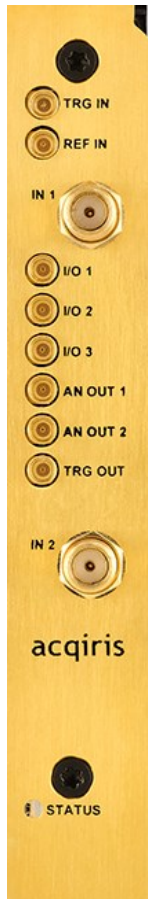

| Connector | Type | Description | | | | | | |
|---------------------------------------|----------------|---|---------|------------|-----------|---------------------------------------|----------------|-------------|
| TRG IN | MMCX female | External trigger input, 50 Ω DC terminated, ± 5 V range. | | | | | | |
| IN 1, 2 | SMA female | Analog signal inputs, DC-coupled and 50 Ω terminated. The input full scale ranges are selectable: <table border="1" data-bbox="657 719 1315 846"> <thead> <tr> <th>Voltage</th> <th>500 mV FSR</th> <th>2.5 V FSR</th> </tr> </thead> <tbody> <tr> <td>Recommended maximum operating voltage</td> <td>± 600 mVpk</td> <td>± 3 Vpk</td> </tr> </tbody> </table> | Voltage | 500 mV FSR | 2.5 V FSR | Recommended maximum operating voltage | ± 600 mVpk | ± 3 Vpk |
| Voltage | 500 mV FSR | 2.5 V FSR | | | | | | |
| Recommended maximum operating voltage | ± 600 mVpk | ± 3 Vpk | | | | | | |
| TRG OUT ¹ | MMCX | Trigger Out signal (programmable). 50 Ω source, LVCMOS 3.3 V | | | | | | |
| I/O 1, 2, 3 | MMCX | User configurable digital Input / Output signal. DC coupling, LVCMOS 3.3 V. Output: 50 Ω source, Input: +5 V max. | | | | | | |
| REF IN | MMCX | External reference clock input, AC coupled and 50 Ω terminated. It can accept a 10 MHz or a 100 MHz signal from -3 to +3 dBm. | | | | | | |
| AN OUT 1, 2 | MMCX | Application dependent analog signal from a 12-bit DAC, controlled by the internal FPGA. DC coupling, 300 Ω source, programmable output up to ± 10 V. | | | | | | |

Note



The ADC card can usually work with signal present at the external reference input (REF IN). However, to ensure the best performance, or if the calibration is found to be unreliable, it is recommended to remove such signals when working with internal clock.

Warning

All the inputs shall not be driver until the SA220P is powered on.

¹The trigger out connector depends on the product version.

Front Panel LEDs

| Indicator | Purpose | Color | State | Meaning |
|---------------|---------------|---|------------------|-----------------|
| STATUS | Module status |  | Orange, blinking | Warning |
| | |  | Red, blinking | Error |
| | |  | White, blinking | OK (card ready) |

Startup sequence

The following table indicates step by step the initialization sequence of the card, with corresponding states of the LEDs.

| Steps | Actions | Front Panel LED | DONE LED | PCIe LEDs | Notes / comments |
|-------|---|-------------------|----------|--------------------------------|---|
| 1 | Turn on the PCIe extender | OFF | OFF | All are ON | The FPGA is not yet programmed |
| 2 | Program the Tandem1 part into the NorFlash using the JTAG cable | OFF | ON | ON | The Xilinx SW tools programs the NorFlash interface into the FPGA |
| 3 | Restart the PCIe extender | ORANGE Solid | ON | OFF | The stage 1 is programmed into the FPGA |
| 4 | Program the Tandem2 using JTAG | BLUE Solid | ON | OFF | The stage 2 is programmed into the FPGA |
| 5 | Start the PC | BLUE intermittent | ON | Follow the PCIe current status | The FPGA is correctly programmed. The module is detected into the Device Manager (Acqiris Signal Acquisition Instruments) |
| 6 | Turn off the PC | WHITE Solid | ON | OFF | The FPGA is always well programmed |
| 7 | Restart the PCIe extender | ORANGE Solid | ON | OFF | The Tandem1 stage is well programmed into the FPGA |

Note

If warning or error status is observed, power-cycle the host computer (if using a PCIe expansion chassis, observe the power sequence requirements).
If the error persists please contact technical support support@acqiris.com.

Step 5: Verify Operation of the SA220P Card

Driver Graphical Interface: MD3 Soft Front Panel

The Acqiris MD3 SFP (Soft Front Panel) is a graphical interface for signal acquisition card drivers that enables the control of any supported ADC cards.

The MD3 SFP can be launched from the:

Windows Start Menu > Acqiris > MD3 > AcqirisMD3 SFP.

The **Connection window** opens with the selection of the ADC card to monitor. After selecting your ADC card click **Connect**. For details, please refer to MD3 SFP Help.

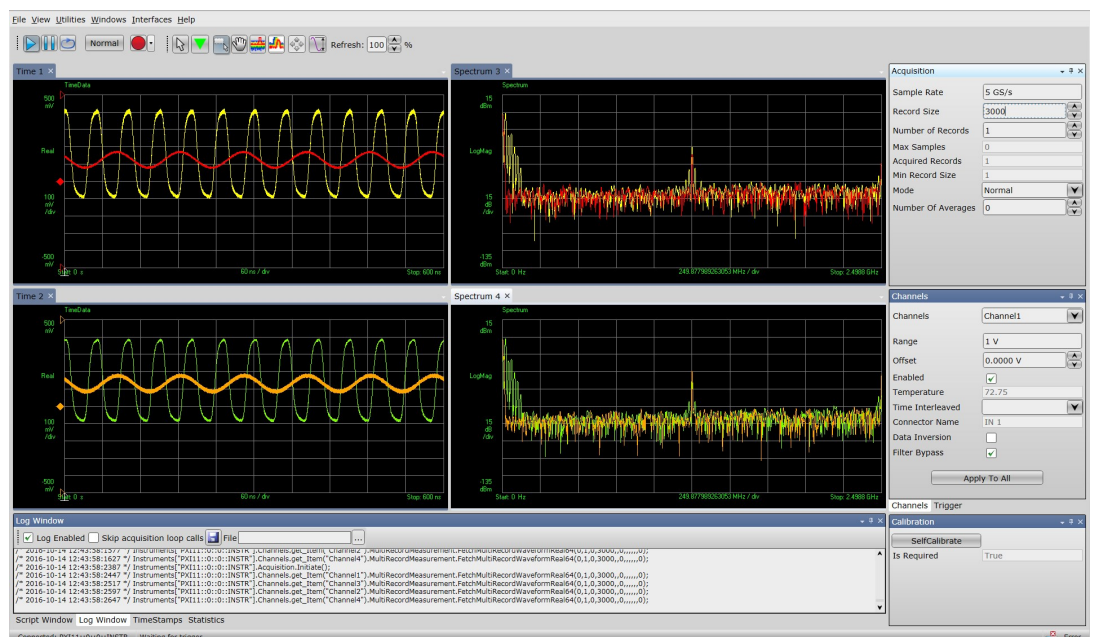

Example of display after running a high-speed ADC card acquisition with the MD3 SFP (Acquisition parameters depends on your ADC card).

Perform a Verification of the SA220P (optional)

Requirements for Verification

The correct operation of the SA220P may be verified by the use of a simple application which carries out several performance checks on a signal acquired from an external function generator.

Required Hardware

An external signal source is required. Almost any sine wave or function generator capable of generating a signal with an amplitude of 300 mV rms into 50 Ω at a frequency of 1 MHz may be used.

| Hardware | Description |
|------------------|--------------------------------|
| Signal Generator | e.g. Keysight N5181B |
| SMA cable | 50 Ω Coaxial cable with SMA(m) |

Operational Verification Procedure

Caution

Do not exceed the maximum voltage level at the input connector (± 3 V DC)

1. Configure the signal generator to produce a sinusoidal signal with a frequency of 1 MHz, and an amplitude of 300 mV rms (+2.55 dBm).
2. Connect the signal generator output to the IN 1 connector, and turn on the output.
3. Launch the **AqMD3Verify** utility from:

Windows Start Menu > Acqiris > MD3 > AqMD3Verify.

A command shell window will open.

```

C:\Program Files\Acqiris\MD3\Bin\AqMD3Verify.exe
AqMD3Verify
=====
Driver identifier: AqMD3
Driver revision: 3.1.0.0
Driver vendor: Acqiris
Driver description: IVI.NET Driver for Acqiris Signal Acquisition Components

0) Verify resource PXI5::0::0::INSTR
Selection? (or [ENTER] to exit) 0
Please connect a sinusoidal signal of 1.0 MHz and 300 mV rms (2.55 dBm) to channel 1 input.
Press any key to continue..
    
```

Select the instrument PXI address, then **Press any key** to start the test.

4. Check that all the test results are OK.

Note

AqMD3Verify utility checks the version of the Control FPGA firmware. If the version is not up-to-date, the tool will automatically propose to update the firmware using the firmware update utility. Once the Control FPGA firmware has been updated successfully, please power off your computer and restart it again for the update to take effect. You may then proceed with the **AqMD3Verify** utility as described in this section.

If a Problem is Found

1. Verify that you have made all configuration settings as shown above.
2. Verify that the signal generator is ON and producing the desired signals at the end of the cable. This can be done with an oscilloscope.
3. Verify that the problem is reproducible.
4. Then, please contact technical support support@acqiris.com.

Related Documentation

If you have run the Acqiris MD3 software installer on your host computer, this Startup Guide and the related product documentation listed below have been installed on your hard drive. The documents listed below are also available for download from Acqiris Extranet.

| Document | Description and location |
|---|---|
| Startup Guide | Includes procedures to help you to unpack, inspect, install (software and hardware), perform card connections, verify operation, and troubleshoot your product. <i>C:\Program Files¹\Acqiris\MD3\Documentation\SA220P\SA220P_StartupGuide.pdf</i> or from Startup Menu > Acqiris > Documentation > SA220P > SA220P_StartupGuide |
| User Manual | Provides in-depth information and reference material specific to your product. <i>C:\Program Files\Acqiris\MD3\Documentation\SA220P\SA220P_UserManual.chm</i> or from Startup Menu > Acqiris > Documentation > SA220P > SA220P_UserManual |
| Data Sheet | In addition to a detailed product introduction, the data sheet supplies full product specifications. The data sheet can be downloaded from https://acqiris.com/SA220P-datasheet |
| Soft Front Panel (help system) | Provides information on the use of the driver Soft Front Panel. <i>C:\Program Files\Acqiris\MD3\Documentation\MD3_SFP_Help.chm</i> or from Startup Menu > Acqiris > Documentation > MD3_SFP_Help |
| IVI Driver reference (help system) | Provides detailed documentation of the IVI.NET and IVI-C driver API functions, as well as information to help you get started with using the IVI drivers in your application development environment. IVI-C : <i>C:\Program Files\IVI Foundation\IVI\Drivers\AqMD3\AqMD3.chm</i> or from Startup Menu > Acqiris > Documentation > AqMD3 IVI Driver <version#> Documentation IVI.NET : <i>C:\Program Files\IVI Foundation\IVI\Drivers\AqMD3\Acqiris.AqMD3.Fx40.chm</i> or from Startup Menu > Acqiris > MD3 > Documentation > AqMD3 IVI.NET Driver <version#> Documentation |

¹Or your installation path

Programming Information

The AqMD3 IVI driver provides access to the functionality of AqMD3 ADC cards through a .NET or ANSI C API which also complies with the IVI specifications.

IVI-C Driver development environments

The **AqMD3 IVI-C** driver can be used in Visual C++ or MATLAB development environment.

IVI.NET Driver development environments

The **AqMD3 IVI.NET** driver can be used in Visual C#, Visual C++/CLI or Visual Basic.NET development environment.

Program examples

Once Acqiris MD3 software is installed, program examples can be found in:

<C:\Program Files\IVI Foundation\IVI\Drivers\AqMD3\Examples\>

This information is subject to change
without notice.
© Acqiris SA 2017 - 2022
Tuesday, February 27, 2024,
Switzerland

www.acqiris.com

